

# 20 ATHERSTONE LN

**Location** 20 ATHERSTONE LN

**Mblu** 15/ 14/ 14/ /

**Acct#** 15-14-14

**Owner** SHURSHKY VLADIMIR &

**Assessment**

**PID** 103553

**Building Count** 1

**topoTopography**

**Utility** Public Water, Septic

## Current Value

Assessment
No Data for Current Valuation

## Owner of Record

**Owner** SHURSHKY VLADIMIR &  
SHURSKY JESSICA E  
**Address** 20 ATHERSTONE LN  
BEDFORD, NH 03110

**Sale Price** \$875,000  
**Certificate**  
**Book & Page** 9191/2440  
**Sale Date** 07/25/2019  
**Instrument** 00  
**Qualified** Q

## Ownership History

Ownership History					
Owner	Sale Price	Certificate	Book & Page	Instrument	Sale Date
SHURSHKY VLADIMIR &	\$875,000		9191/2440	00	07/25/2019
DAVIDSON DIANE	\$195,000		7953/0240	00	02/26/2008
COOKE R.D. CO INC	\$180,000		7916/2587	00	11/01/2007
MCQUADE BROOK LLC	\$1,150,000		7811/0772	1N	02/23/2007
LYSCARS WILLIAM TRUSTEE	\$100		7172/2472	1N	02/24/2004

## Building Information

### Building 1 : Section 1

**Year Built:** 2007  
**Living Area:** 3,157

Replacement Cost: \$753,439

Building Percent Good: 85

Replacement Cost

Less Depreciation: \$640,400

**Building Attributes**

Field	Description
Style:	Conventional
Model	Residential
Grade:	Very Good +20
Stories:	2
Occupancy	1
Exterior Wall 1	Vinyl Siding
Exterior Wall 2	
Roof Structure:	Gable/Hip
Roof Cover	Asph/F GlS/Cmp
Interior Wall 1	Drywall/Sheet
Interior Wall 2	
Interior Flr 1	Hardwood
Interior Flr 2	Carpet
Heat Fuel	Gas
Heat Type:	Forced Air-Duc
AC Type:	Central
Total Bedrooms:	4 Bedrooms
Total Bthrms:	4
Total Half Baths:	1
Total Xtra Fixtrs:	
Total Rooms:	9 Rooms
Bath Style:	Modern
Kitchen Style:	Modern
Num Kitchens	
Cndtn	
Num Park	
Fireplaces	
Fndtn Cndtn	
Basement	

**Building Photo**



(<https://images.vgsi.com/photos/BedfordNHPhotos/\00\00\80\56.jpg>)

**Building Layout**

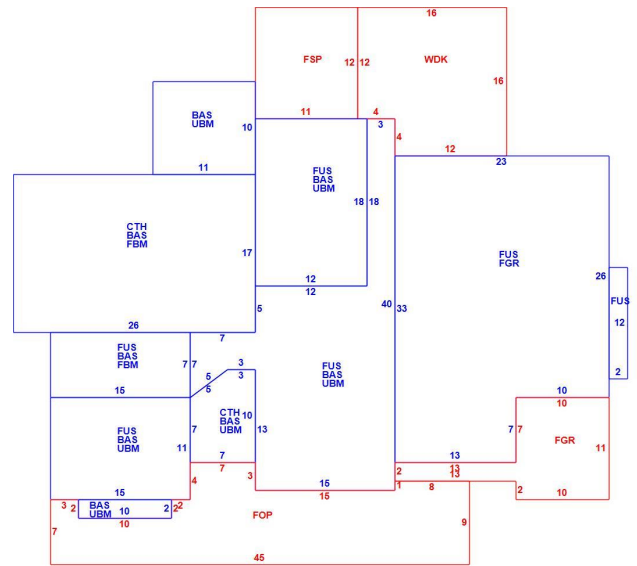

(ParcelSketch.ashx?pid=103553&bid=104197)

Building Sub-Areas (sq ft)			Legend
Code	Description	Gross Area	Living Area
FUS	Upper Story, Finished	1,617	1,617
BAS	First Floor	1,540	1,540
CTH	Cathedral Ceiling	506	0
FBM	Basement, Finished	547	0
FGR	Garage, Framed	825	0
FOP	Porch, Open	354	0
FSP	Porch, Screen	132	0
UBM	Basement, Unfinished	993	0
WDK	Deck, Wood	240	0
		6,754	3,157

**Extra Features**

Extra Features					<u>Legend</u>	
Code	Description	Size	Value	Assessed Value	Bldg #	
FPL	FIREPLACE	1.00 UNITS	\$1,200	\$1,200	1	
WHL	WHIRLPOOL	1.00 UNITS	\$3,100	\$3,100	1	
FPL3	2 STORY CHIM	1.00 UNITS	\$4,500	\$4,500	1	

**Land**

Land Use		Land Line Valuation	
Use Code	1010	Size (Acres)	1.54
Description	SINGLE FAM MDL-01	Frontage	
Zone	RA	Depth	
Neighborhood	90	Assessed Value	\$0
Alt Land Appr	No		
Category			

**Outbuildings**

Outbuildings							<u>Legend</u>
Code	Description	Sub Code	Sub Description	Size	Value	Assessed Value	Bldg #
SHD1	SHED FRAME			120.00 S.F.	\$1,600	\$1,600	1
PAT1	PATIO-AVG			246.00 S.F.	\$700	\$700	1
SPL3	GUNITE			566.00 S.F.	\$13,200	\$13,200	1
PAT2	PATIO-GOOD			1000.00 S.F.	\$6,000	\$6,000	1
CNP1	CANOPY-AVG			252.00 S.F.	\$2,800	\$2,800	1

**Valuation History**

Assessment					
Valuation Year	Building	Extra Features	Outbuildings	Land	Total
2022	\$640,400	\$8,800	\$24,300	\$261,600	\$935,100
2021	\$635,700	\$4,400	\$11,900	\$261,600	\$913,600
2020	\$624,100	\$4,500	\$3,900	\$207,800	\$840,300